



# SMART DOOR LOCK



## INSTRUCTION MANUAL



MIFARE



PASSWORD



MECHANICAL KEY



PALM VEIN



FACE



APPS



FINGERPRINT

SCAN THIS QR CODE TO DOWNLOAD THE APPLICATION



OR DOWNLOAD APPS 'Tuya' ON GOOGLE PLAY OR APPSTORE

## Accessories

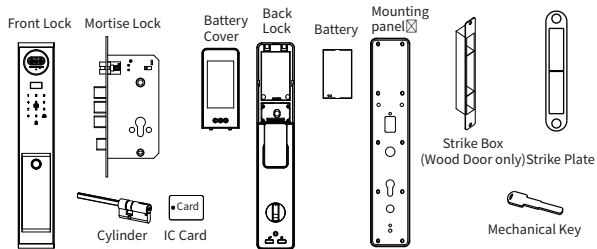

Door thickness Quantity	Connecting Spindle	Connecting Pillar	Connecting Screw	Screw
37-39mm	8*8*75mm	4*5*35mm x 2	M4*30mm x 5	4.2*25mm X 4
40-50mm	8*8*75mm	4*5*35mm x 2	M4*45mm x 5	4.2*25mm X 4
51-60mm	8*8*90mm	4*5*45mm x 2	M4*45mm x 5	4.2*25mm X 4

## Product Overview

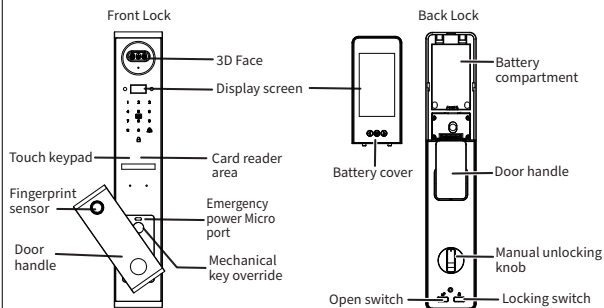

## Specification

No.	Item	Specification
1	Comparison model	1: N
2	Rejection rate	<0.1%
3	False recognition rate	<0.001%
4	Fingerprint collection range	±180°
5	Card type	M1
6	User capacity	Total capacity: 250 Fingerprint maximum capacity: 100 Password maximum capacity: 100 ; IC Card maximum capacity: 100 Face capacity: 100; Palm vein maximum capacity: 100. The total capacity cannot exceed 250. Administrator ID: 00-09 Regular User ID: 10-249
7	Operation record	600 pieces
8	Battery life	Opening times ≥3000
9	Working voltage	4.9V~6.0V, Low voltage alarm voltage ≤4.9V
10	Dynamic power consumption	≤1A(No motor action, no playing sound)
11	Static power consumption	≤100uA (average power consumption)
12	Verification time	≤3s, (including the whole process of fingerprint collection, comparison and unlocking signal output)
13	Keyboard type	Touch sensing
14	External emergency power supply	5V1A Type-C USB
15	Resistance to static electricity	≥8KV (contact) ≥15KV(Non-contact)
16	Storage temperature	-25°C ~ 80°C
17	Working temperature	-25°C ~ 70°C
18	Ambient humidity	15%RH~93%RH

## Installation Guide

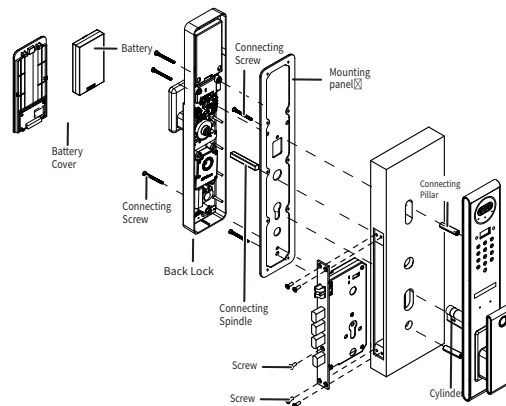

## Adjust The Mortise Direction

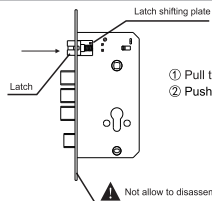

- ① Pull the Latch shifting plate to another side
- ② Push the latch into the mortise and turn 180 degree

⚠ Not allow to disassemble the face plate

## Caution Before Installation

- 1) Do not use strong force during installation to avoid damaging the lock
- 2) Use correct installation tools
- 3) Wear safety glass to protect your eyes when drilling holes



- 4) Do not drill the door hole on both of the door to avoid damaging the door plate



## Installation

### 1. Install mortise

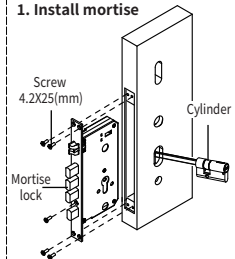

### 2. Install the front panel

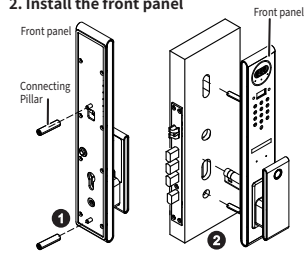

## Installation

### 3. Install mounting panel

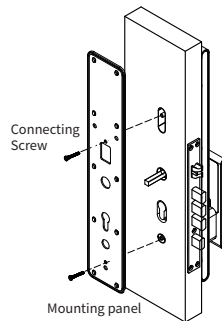

### 4. Install the back panel

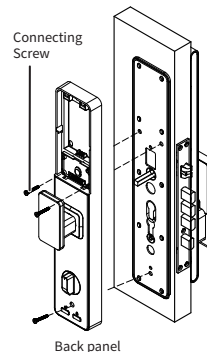

### 5. Install batteries

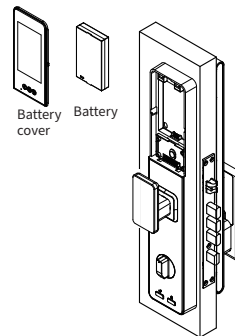

### 6. Install strike box & strike plate

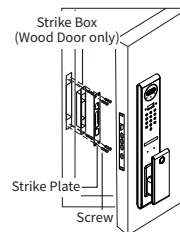

## The menu structure is shown in the figure

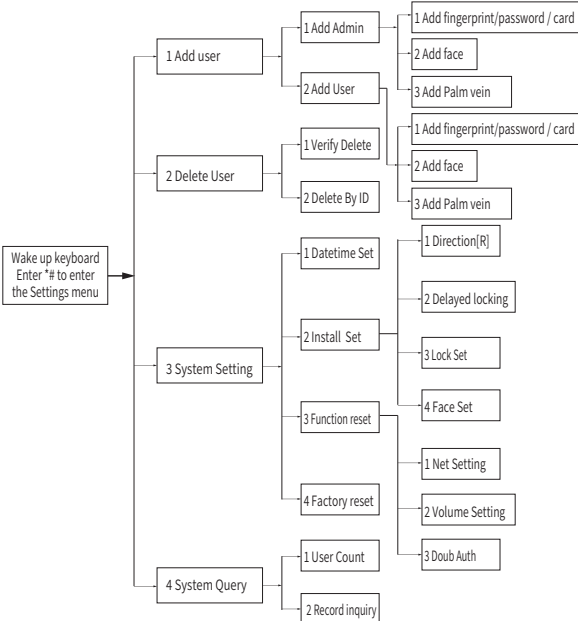

## Check Point After Installation

1. Front body and main body are parallel with the side jamb
2. Test and verify the connection and the installation of the manual thumb turn, mechanical key override and unlock/lock button
3. Test and verify the functionality of the deadbolt from both the front body and the back body
4. Pull the front body handle hard and ensure no false tampering alarm is triggered
5. Check the door panel condition, ensure no swaying after the deadbolt is protruded into the side jamb

## Lock Operation

### 1. Doorbell function

Touch the buttons  with your fingers, Smart lock rings the doorbell immediately.

### 2. Restore factory settings

Long press and hold the open and lock switch button at the back panel, and the voice prompt "Restore factory settings, confirm by pressing the # key, cancel by pressing the \* key". Press the # key to confirm, and the system will restart to factory mode.

In the factory state, any fingerprint, password, face, palm or card can unlock the lock. Performing factory settings cannot clear the already set door opening direction and torque parameters.

### 3. Low battery warning

If the system's battery level is less than 25%, the system will voice prompt "Low battery, please replace the battery" when unlocking. The battery can still be unlocked about 50 times, but please charge it in a timely manner (or replace the battery). The lock is powered by a rechargeable lithium battery. Please charge using a 5V1A charger.

### 4. External Type-c emergency power supply

When the battery is low or completely out of charge, you can connect a data cable to a power bank and plug it into the Type-C port on the front lock body to supply emergency power to the lock. It will take about 30 seconds for the lock to power up.

### 5. Illegal user alarm

Enter either the wrong fingerprint, password, face, palm or card 5 times in a row, the system will prompt "Illegal user, illegal intrusion, owner notified" and locks it for 360 seconds. During this period, there will be no response to user actions. Lock-out will be lifted after 360 seconds.

### 6. Virtual password

The door lock has added a digital password virtual function. When using a password to unlock, users can add numbers before and after the correct password, and press the "\*" key to confirm. This can increase the security of the digital password, but the total length of the input should not exceed 16 digits.

### 7. View version number

Enter 222 # to view the software version number.

### 8. Open the mechanical keyhole

Press the button inside the handle and turn the handle left or right to see the keyhole.

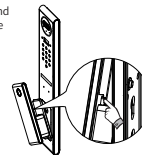

## Factory setting

Please note: Before you can start using this lock, you must register a new administrator. If not, you cannot configure a Wi-Fi-enabled lock. The procedure is as follows:

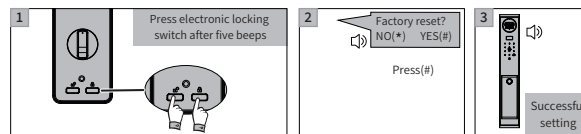

## Lock Operation

### 1. User settings add administrator password for the first time

1 Press [\*] then [Enter]

2 Enter 6-8 digit password, press the [Enter] key to confirm.  
Add management user, Please enter 6-8 digit password, press the [Enter] key to confirm.

3 Enter the same set of password  
Please enter the same password again

4 User 000 added successfully

\* After added user successfully, the system will automatically turn to the main menu, and the user can exit or perform other operations based on voice navigation.

### 2. Add administrator

\* In addition to being able to open and close locks normally, administrator can also enter the main menu of the system to add or delete users. administrator can add up to 10.

#### 2.1 Add administrator fingerprint, password and card

1 Press [\*] then [Enter]

2 Entering administrator information for verification.  
Entering administrator information for verification.

3 Press[1]  
[1] Add User  
[2] Delete User  
[3] System Setting  
[4] System Query

4 Press[1]  
[1] Add Admin  
[2] Add user

5 Press[1]

6 Password  
Add fingerprint /password/card information

**Note:**

- Number 00-09 is the administrator user ID, and 10-249 is the regular user ID.
- Please ensure user IDs assigned are recorded. The user ID is required for the deletion of the respective PIN code user.

1) fingerprint input 5 times, password input 6-8 digits twice, IC card input once.

## Lock Operation

### 2.2 Add administrator face

1 Press [\*] then [Enter]

2 Entering administrator information for verification.  
Entering administrator information for verification.

3 Press[1]  
[1] Add User  
[2] Delete User  
[3] System Setting  
[4] System Query

4 Press[1]  
[1] Add Admin  
[2] Add user

5 Press[2]

6 Add face information  
Face

1) After hearing "Please enter the front face", place the face parallel to the camera at the distant of 40-80CM  
2) Follow the prompts to register the face in 5 directions

**2.3 Add administrator palm vein**

1 Press [\*] then [Enter]

2 Entering administrator information for verification.  
Entering administrator information for verification.

3 Press[1]  
[1] Add User  
[2] Delete User  
[3] System Setting  
[4] System Query

4 Press[1]  
[1] Add Admin  
[2] Add user

5 Press[3]

6 Add face information  
Palm vein

1) After hearing "Please place your palm in front of the camera", place your hand parallel to the front of the camera at a distant of 10-25cm  
2) Follow the prompts to register the palm vein once

## Lock Operation

### 3. Add user

\* Regular users only have unlock permission and can add up to 240

#### 3.1 Add user fingerprint, password and card

**1** Press [\*] then [A]

**2** Entering administrator information for verification.

**3** Press[1]

**4** Press[2]

**5** Press[1]

**6** Add fingerprint, password, card information

**Note:**

- Number 00-09 is the administrator user ID, and 10-249 is the regular user ID.
- Please ensure user IDs assigned are recorded. The user ID is required for the deletion of the respective PIN code user.

1) fingerprint input 5 times, password input 6-8 digits twice, IC card input once.

#### 3.2 Add user face

**1** Press [\*] then [A]

**2** Entering administrator information for verification.

**3** Press[1]

**4** Press[1]

**5** Press[2]

**6** Add face information

1) After hearing "Please enter the front face", place the face parallel to the camera at the distant of 40-80CM

2) Follow the prompts to register the face in 5 directions

## Lock Operation

### 3.3 Add user palm vein

**1** Press [\*] then [A]

**2** Entering administrator information for verification.

**3** Press[1]

**4** Press[2]

**5** Press[3]

**6** Add face information

1) After hearing "Please place your palm in front of the camera", place your hand parallel to the front of the camera at a distant of 10-25cm

2) Follow the prompts to register the palm vein once

## Lock Operation

### 4. Delete User

#### 4.1 Verify Delete

1 Press [\*] then [A]

2 Entering administrator information for verification.

3 Press[2]

4 Press[1]

5 Enter user info to delete

6 Continue to delete Press the [\*] to return

Delete successful

#### 4.2 Delete By ID

1 Press [\*] then [A]

2 Entering administrator information for verification.

3 Press[2]

4 Press[2]

5 Enter user ID to delete

6 Continue to delete Press the [\*] to return

Delete successful

Note:  
If the user exists in the system, the voice prompt will be "Successfully deleted, can be deleted continuously, please press the \* key to exit";  
If the user does not exist, the voice prompt "Operation failed" will appear.

## Lock Operation

### 5. System Setting

#### 5.1 Time setting

1 Press [\*] then [A]

2 Entering administrator information for verification.

3 Press[3]

4 Press[1]

5 Enter datetime  
eg. 202306171826

6 success

#### 5.2 Install Set

##### 5.2.1 Direction & Auto-lock setting

1 Press [\*] then [A]

2 Entering administrator information for verification.

3 Press[3]



4 Press[2]

5 Press [1] for direction OR Press [2] for auto-lock

6 [1] Direction[R]  
[2] Auto-lock[H]  
[3] Lock Set  
[4] Face Set

## Lock Operation

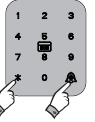
### 5.2.2 Lock Set or Face Set

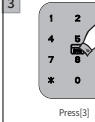
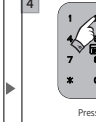
**1**  **2**  **3**  **4** 

Press [\*] then 

Entering administrator information for verification.



Press[3]

Press[2]

 (1) Add User  
(2) Delete User  
(3) System Setting  
(4) System Query

 (1) Datetime Set  
(2) Install Set  
(3) Function Set  
(4) Factory reset

### Lock Set

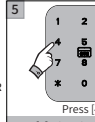
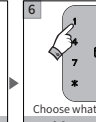
**5**  **6**  OR **5**  **6** 

Press [3]

Press [4]

Choose what you need

Choose what you need



 (1) Direction[R]  
(2) Auto-lock[H]  
(3) Lock Set  
(4) Face Set

 (1) Tamper Alarm [Y]  
(2) Motor Torque[L]  
(3) Lock back[65]  
(4) Dwell.Alert[N]

 (1) Direction[R]  
(2) Auto-lock[H]  
(3) Lock Set  
(4) Face Set

 (1) Auto Detect [N]  
(2) Distance [L]  
(3) Prompt[Y]

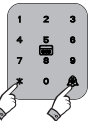
### 5.3 Function Set

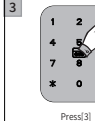
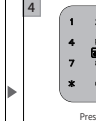
**1**  **2**  **3**  **4** 

Press [\*] then 

Entering administrator information for verification.

Press[3]

Press[3]

 (1) Add User  
(2) Delete User  
(3) System Setting  
(4) System Query

 (1) Datetime Set  
(2) Install Set  
(3) Function Set  
(4) Factory reset



**5** 

Choose what you need

 (1) Net setting  
(2) Volume[H]  
(3) Doub Auth[N]

## Lock Operation

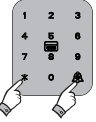
### 5.4 Factory reset

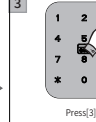
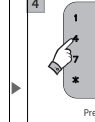
**1**  **2**  **3**  **4** 

Press [\*] then 

Entering administrator information for verification.

Press[3]

Press[4]

 (1) Add User  
(2) Delete User  
(3) System Setting  
(4) System Query

 (1) Datetime Set  
(2) Install Set  
(3) Function Set  
(4) Factory reset



**5** 

Press[#]

Factory reset?  
NO[\*] YES[#]

### 6. System Query

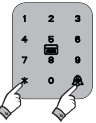
#### 6.1 User Count

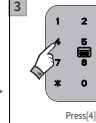
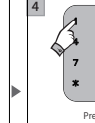
**1**  **2**  **3**  **4** 

Press [\*] then 

Entering administrator information for verification.



Press[4]

Press[1]

 (1) Add User  
(2) Delete User  
(3) System Setting  
(4) System Query

 (1) User Count  
(2) Record inquiry

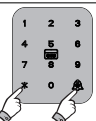
#### 6.2 Record inquiry

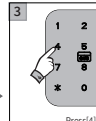
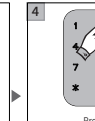
**1**  **2**  **3**  **4** 

Press [\*] then 

Entering administrator information for verification.

Press[4]

Press[2]

 (1) Add User  
(2) Delete User  
(3) System Setting  
(4) System Query

 (1) User Count  
(2) Record inquiry

## Lock Operation



Choose according to your needs

- 1) Inquiry by order
- 2) Inquiry by time

## APP configuration(Tuya smart)- optional

- 1) Search "Tuya Smart" in App Store or an App market, download and install it.
- 2) Register with your cellphone number and log in.
- 3) Click "Camera & Lock", find "Smart Gating(Wi-Fi)", click and add a device following instructions before use
- 4) Remote unlocking: Press the "#" key in sleep mode, and the system will automatically request remote unlocking and issue a prompt on the APP.

### Add one network

- 1) Press "\*" + "#" to authenticate administrator identity and then press "1" to access administrator settings. Then there will be a voice prompt of pressing "4" for network configuration.
- 2) At this point, open the app and follow the prompts to operate.
- 3) When the network is successfully added, a voice prompt of "successful" will appear.
- 4) If the network addition fails or the connection times out, a voice prompt of "failed" will appear.

### Note:

Please add administrator before any setting

## Other notes

1. When either face, fingerprint, card, palm or PIN code accumulated with 5 failed attempts, 360 seconds lock-out will be triggered.
2. Password peeping prevention function: Fake password can be added either at the front or the back of the administrator or user code to minimize the leakage of the actual password.
3. If there is no operation for more than 10 seconds, the system will automatically exit.

## APP Operation



### 1.APP REGISTRATION AND LOGIN

- APP registration: if you do not have an APP account, you can choose to register or log in by SMS verification code.
- Click "create a new account" to enter the account registration page. According to the prompt to obtain SMS verification code, set the password.
- If you have an existing account, click "login with an existing account" to log into the APP. Password, verification code, and social account login are supported.

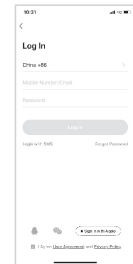

### 2.CREATE HOMES

- Create your home after registering and logging in successfully.
- Each account can create and add multiple homes, and devices can be grouped by room in the home
- Weather and other functions depend on the geographical location of the family, which is recommended to set in advance.

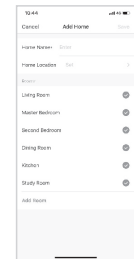

## APP Operation

### 3.ADD WIFI LOCK

- On the "My Home" tab, click the "+" icon in the upper right corner to open the interface shown in Figure 1. Select Smart Gating (Wi-Fi) under "Camera & Lock" to enter the page shown in Figure 2.
- Once the device enters connection mode, follow the on-screen instructions and app prompts to continue the setup.

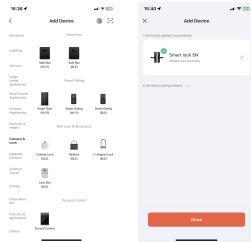

### 4.HOME PAGE

- Home page includes remote unlock, alarm message, member management, records, temporary password and other functions.
- Remote Unlock: press the door bell on the door lock, and the app can respond to allow /reject door opening.

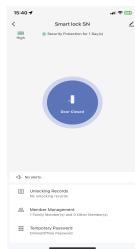

### 5.TEMPORARY PASSWORD

- Can generate "One-Time Password" and "Time-Limited Password"
- One Time Password: can only be used once during the validity period. The validity period is six hours.
- Time Limited Password: Within the set validity period, there is no limit to the number of times the password can be used to unlock the door

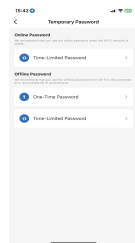

## APP Operation

### 6.ALERTS MESSAGE CENTER

- Message center contains alarm information, door bell call information and hijacking alarm information, which can be inquired.

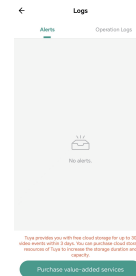

### 7.MEMBER MANAGEMENT

- User can be added, deleted or changed in member management.
- Only the administrator user of app is allowed to do that.

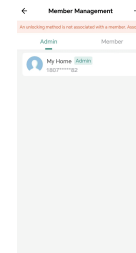

### 8.UNLOCKING RECORD

- 24/7 Record Log, arranged in reverse chronological order. The unlocked ID with the associated user name will directly display the user name, while the unlocked ID without the associated name will display the specify unlock ID

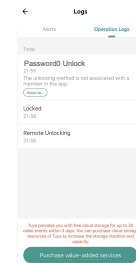

## Important notes

1. Do not install the product in an outdoor environment with direct exposure to weather.
2. Do not use the device in the environment at too high or too low temperature, never expose the device under strong sunshine or too wet environment. The suitable temperature for the product and accessories is  $-25^{\circ}\text{C}$ ~ $+80^{\circ}\text{C}$ .
3. To prevent dirt on keypad and fingerprint area sensor, we recommend to use soft cloth for wipes. Do not spray water directly or wipe with chemicals such as benzene, gasoline or alcohol.
4. It is recommended to replace / recharge the battery immediately when "replace the batteries" reminder is triggered to avoid any inconvenience.
5. When the battery is out, an emergency power supply can be provided through the emergency power supply port via type-C USB cable for emergency access (not for charging)
6. When charging, please place the device in an environment that has a normal room temperature and good ventilation. It is recommended to charge the device in an environment with a temperature that ranges from  $1^{\circ}\text{C}$ ~ $45^{\circ}\text{C}$ . Please make sure to use a 5V 1A charger from the reputable manufacturer. Using unauthorized charger may cause danger and violate the authorization of the device and the guarantee article.
7. Warning:
  - replacement of a battery with an incorrect type that can defeat a safeguard;
  - disposal of a battery into fire or a hot oven, or mechanically crushing or cutting of a battery, that can result in an explosion;
  - leaving a battery in an extremely high temperature surrounding environment that can result in an explosion or the leakage of flammable liquid or gas; and
  - a battery subjected to extremely low air pressure that may result in an explosion or the leakage of flammable liquid or gas.
8. The mortise may be damaged if the door is closed hard with the deadbolt protruded.
9. Please keep at least 1 mechanical key override out of the house (office / parents' house) for emergency use when needed.